

SUMMER SUZUKI VIOLA LESSONS

GOALS: RHYTHMS IN $\frac{2}{4}$, $\frac{4}{4}$, C AND C

Musical notation examples for various rhythms and patterns, including eighth notes, sixteenth notes, and triplet patterns.

KEYS OF D, G, C, AND B FLAT
FINGER PATTERNS OF:

0 1 23

A & D Strings: *Twinkle to May Song*

0 1 23 4

D & G Scales: 1 octave; to *Perp.Motion*

0 1 23 4

G & C Strings: *Allegretto to Andantino*; *Twinkle on C string*; C scale - 2 octaves

0 12 3 4

Bohemian Song to Minuet 1

0 1 2 34

Minuet 2 to Gavotte

01 2 34

B^b Scale and *Lightly Row in B^b*

LESSON PLANS

- LESSON 1 *Change strings; Posture; Bow Hold (see p. 5 & 27); "LISTEN & PLAY" to adjust students to format of lessons; "STOP & PREPARE" (mind, fingers, bow, play)*
D Scale and Twinkle 5 ways: A California Stop Sign
 Hand out Tapes (or records) B Throw Away 3 (1 2 - 4)
 DO NOT HAND OUT BOOKS C Stop Berries, Stop Berries
 D Watermelon, Watermelon
 Theme (stop bows)
- LESSON 2 *3 Feeling (still in "steps"): French Folk Song (p mf f)*
 4
Skips and Steps: Lightly Row (add mp) (form: A A¹ B A)
Third finger hop: Song of the Wind (mf p mf) LIFT & SET THE BOW
Study p. 27
- LESSON 3 *Review all pieces and technics (posture, bow hold, listen & play, stop & prepare, D Scale, Twinkle, French Folk Song, Lightly Row, lift and set, and Song of the Wind)*
Go Tell Aunt Rhody - uses steps
O Come, Little Children - uses skips; UP stop UP bow technic
May Song - stop bow at the dot.
Twinkle Variations and Theme on G & D strings
study p. 27

- LESSON 4 teach fourth finger - see rote exercises: p. 14
 Long, Long Ago - uses first finger on G; teach *diminuendo*
 Allegro - contrast legato and staccato; teach fermata
 Perpetual Motion - hear skips and steps; use 4 and 0; form ABCA
 study p. 28
- LESSON 5 Review all pieces and technics from first 2 weeks
 Perpetual Motion - start variation (legato); also teach regular
 part (still staccato) but starting on G string
 Rote: p. 17 Tonalization and G Scale (study p. 28)
 Allegretto - using G string; i am MAD, using accent, rit. and fermata
- LESSON 6 Andantino - I am mad; up bow accent
 Close 1-2 pattern: teach by rote, 1 bar at a time: see p. 18
 Twinkle on C: finally use C String!
 C Scale - two octaves - teach by rote, 1 bar at a time
- LESSON 7 Review all pieces and technics from first 3 weeks
 Diminished 5ths - teach by rote one bar at a time - p. 20
 Bohemian Folk Song - first solo using close 1-2 pattern
 Tonalization - p. 21 teach by rote - 4 notes at a time
- LESSON 8 Etude - teach by rote 4 notes at a time - work on how to memorize
 expect they'll need more time to learn this one
- LESSON 9 Review all pieces and technics from first 4 weeks
 Bowing patterns for Minuet 1 - see p. 22 - teach by rote
 continue to work on problem from Etude: using HIGH 2 or LOW 2???
- LESSON 10 Begin work on reading by using FLASHCARDS - find similar patterns
 in Twinkle to "O Come"
 Note reading treble clef and alto clef on D string
 Minuet 1 - down up up bowing; continue to work on HIGH 2 - LOW 2
- LESSON 11 Review all pieces and technics from first 5 weeks
 Note reading treble clef and alto clef on A string
 Rhythm Flashcards - look for similar patterns in May Song to
 Andantino
 Minuet 2 - start first half; triplets; low-high 2; see p. 28 exercises
 and work on bow distribution (UH or LH?), (1) to (4); finger hops
- LESSON 12 Note reading on G string in treble and alto clef
 Review rhythm flash cards, bowing open strings (Twinkle to Andantino)
 Begin reading book: HAND OUT BOOK TODAY! pages 8 - 15 practice
 Minuet 2 - start second half; sharp 3 finger; see exercises (5) & (6)
- LESSON 13 Review all pieces and technics from first 6 weeks
 Note reading treble clef on E string; alto clef on C string
 Note Reading in book - practice pages 8 - 19
 Minuet 3 - start first half; see p. 30; exercises (1) to (4)
 continue to work on LOW-HIGH 2
- LESSON 14 Minuet 3 - start second half; use exercises (5) to (7)
 Note Reading - p. 8 - 23
 Rhythm flashcards - Twinkle to Minuet 3 (find similar patterns)
- LESSON 15 Review all pieces and technics from first 7 weeks
 Happy Farmer - use music to learn; down-down-up-up bowing (hooks)
 explain p. 31 (1) use (1) to (4) exercises
 Review all 3 keys: D, G, C
 Rote: LOW 1 fingering - teaching B^b 1 octave scale & Lightly Row in B^b
- LESSON 16 exercises for Gavotte p 32 (1) to (2)
 Review Twinkle to Happy Farmer (memorized!); all 4 keys: D, G, C, B^b
 Lightly Row in B^b and all Rhythm Patterns

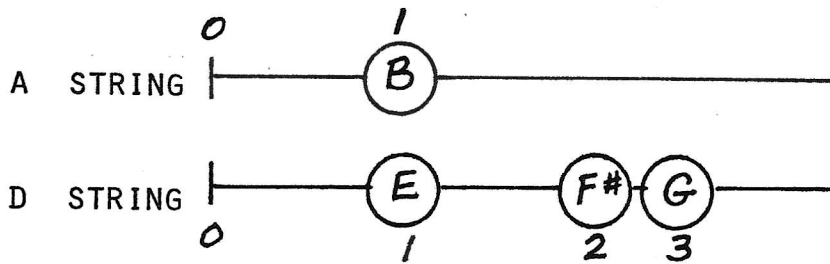





NOTES FOR "TWINKLE, TWINKLE LITTLE STAR"

A STRING	A B A	A	A
D STRING	D G F E D	G F E	G F E

softer - - - - -

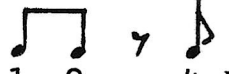
A STRING	A B A
D STRING	D G F E D

RHYTHMS FOR "TWINKLE"

VAR. A		VAR. B			
	CALIFORNIA STOP SIGN		THROW AWAY 3 (1 2 - 4)		
VAR. C			VAR. D		
	STOP BERRIES	STOP BERRIES	WATERMELON, WATERMELON		

THEME OF "TWINKLE"

A STRING	A A B B A
D STRING	D D G G F F E E D
A STRING	A A A A
D STRING	G G F F E G G F F E

now play first line of Theme

softer - - - - -

REVIEW **D SCALE**

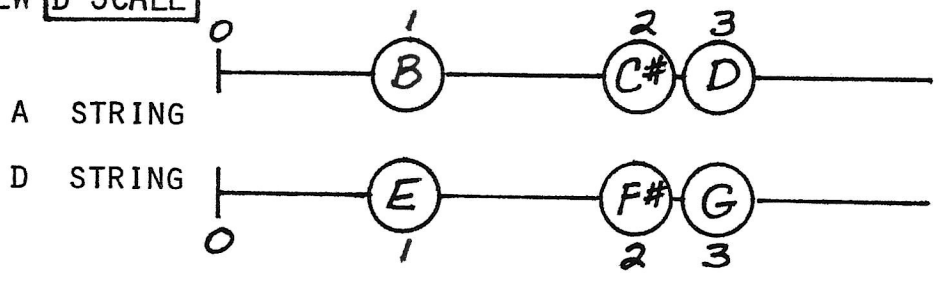

FRENCH FOLK SONG

A STRING *mf* D D D | C C C | B C D | A

D STRING G G G | F F F | E E E | D *p* D E F | D E F | D E F | G

A STRING E F G | E F G | E F G | A | D C B | A

D STRING *mf* E F G | E F G | E F G | A | *f* D C B | A | G F | E D E | D

LIGHTLY ROW

A STRING A AAA

D STRING *mf* FF GEE DEFG

A STRING A AA

D STRING FFF GEEE DF FFF

A STRING A

D STRING *p* EEEEEFG *mp* FFFFFG *now play second line*

SONG OF THE WIND

play whole song twice

A STRING A A A A B D B A **//** B D B A **//**

D STRING *mf* D E F G G *p* G

A STRING A A **//** A

D STRING *mf* G G G G F F F F E E E D F G G G G F F F F E E E D **//**

means "lift and set" (arrow pointing to //)

always REVIEW previous lessons; improve POSTURE, BOW GRIP, MEMORY, BEAUTIFUL TONE

GO TELL AUNT RHODY

A STRING	_____	A A	_____	
D STRING	F FED D E E FED	GF F EDEFD		
A STRING	<i>mf</i> A A B B A	A A B B A		<i>now</i>
D STRING	F FG _____ GF	F FG _____		<i>play</i>
		<i>p</i>		<i>first line</i>

O COME, LITTLE CHILDREN

play whole song twice ALWAYS START UP BOW

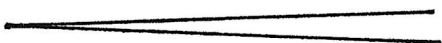
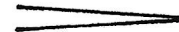
A STRING	<i>v</i> AA AA A	<i>v</i> AA AA A	
D STRING	F FG EEF	F FG EEF	
A STRING	<i>v</i> _____ B	<i>v</i> BA AAD A	
D STRING	FE EEG GGF FF	FG EED	
		<i>f</i>	

MAY SONG

stop bow at dot • *play whole song twice*

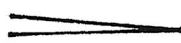
A STRING	A D B DBA	A	
D STRING	D • F	G • F D E • D	
A STRING	A A _____ A	A A _____ A	<i>now play</i>
D STRING	G G F FE	G G F FE	<i>first</i>
	<i>mf</i> 	<i>p</i>	<i>line</i>

REVIEW TWINKLE

STARTING ON G STRING NOW

REVIEW PREVIOUS LESSONS

LONG, LONG AGO

<p>A STRING D STRING</p>	<p>A BA D DEF FG F</p>	<p>A GFE G FED</p>	
	<i>mf</i>		
<p>A D</p>	<p>A BA D DEF FG F</p>	<p>A GFE FED</p>	<p>//</p>
	<i>f</i>		
<p>A STRING D STRING G STRING</p>	<p>A GFE G FED AA</p>	<p>A GFE G FED AA</p>	<p>now play second line</p>
	<i>f</i>	<i>mp</i>	

ALLEGRO

<p>A D</p>	<p>D D A A BCDBA A G G F F EDEFD</p>	<p>// D D A A BCDBA A G G F F EDEFD</p>	<p>//</p>
<p>A D</p>	<p>B B A B B A B C D B A D D F E</p>	<p>D D A A BCDBA A G G F F EDEFD</p>	

PERPETUAL MOTION

<p>A D</p>	<p>D E F F E F G G F G F G E A A A D E F F E F G G F G F G E D D</p>
<p>A D</p>	<p>D C B B C B A A B A A A D C B B C B A A B A G G F E G G F E D D</p>
<p>A D</p>	<p>F E D D G E F F F G A B C D D F E D D G E F F F G A B C D D</p>
<p>A D</p>	<p>D E F F E F G G F G F G E A A A D E F F E F G G F G F G E D D</p>

VARIATION: PLAY WHOLE SONG USING DOUBLE NOTES: D D E E F F F F

REVIEW PREVIOUS LESSONS - CAN YOU PLAY ALL SONGS MEMORIZED?

PERPETUAL MOTION - NOW TRY STARTING ON G STRING

TONALIZATION

D STRING	D	G	D	repeat	E	G	E	
G STRING	G	B	B	G	G	C	C	G

G SCALE

D STRING	D	E	F	G	G	F	E	D
G STRING	G	A	B	C	C	B	A	G

D STRING	E	F#	G
G STRING	A (1)	B (2)	C (3)

ALLEGRETTO

D	D	ED	D	D				
G	GAB	BC	C	CB	BC	CBA	ACB	BAG
D	D	ED	D	D				
G	GAB	BC	C	CB	BC	CBA	BAG	
D				D	ED	DGD		
G	GBA	ACB	GGG	B	C	C	C	B
C	DDD							

mf *rit.*

now play second line

ANDANTINO

D	D	D	EFG	GFE	D			
G	BC	CBA	BAG	A	BC			
D	D	D	EFG					
G	BC	CBA	BAG	A	BC	CBA	G	
A	B	B		A				
D	G	D	EFG	D	G	F	E	D
G								

f *rit.*

now play second line

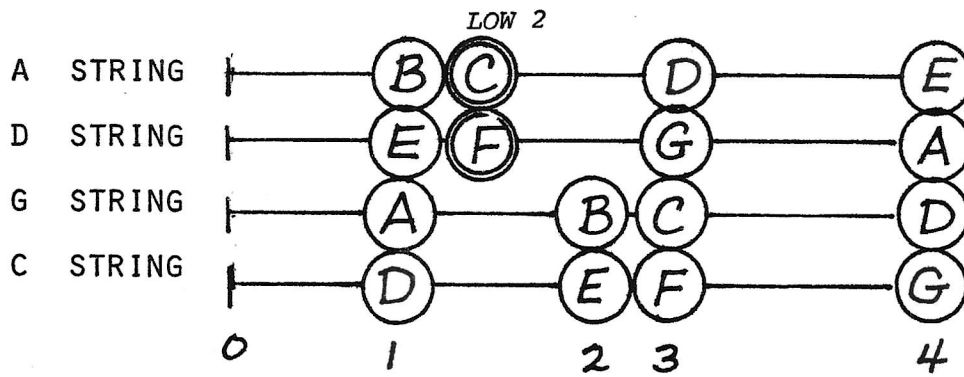

C SCALE

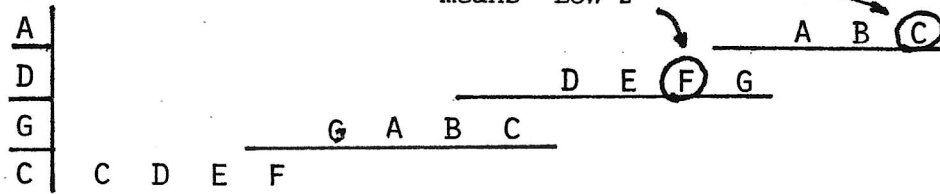

BOHEMIAN FOLK SONG

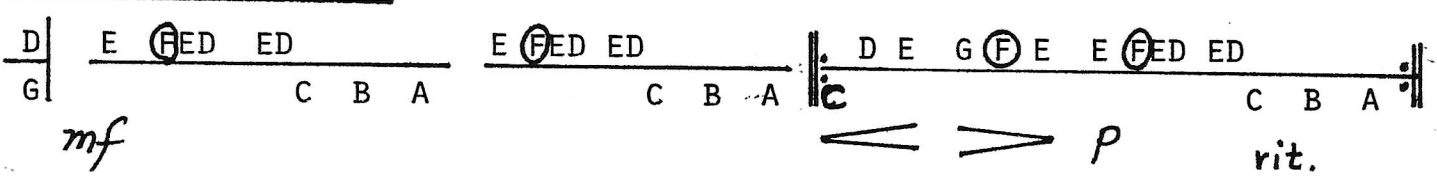

TONALIZATION

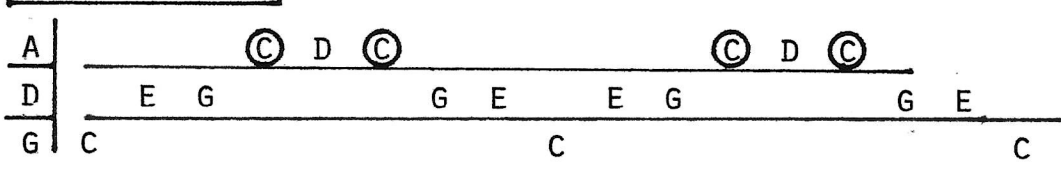

ETUDE

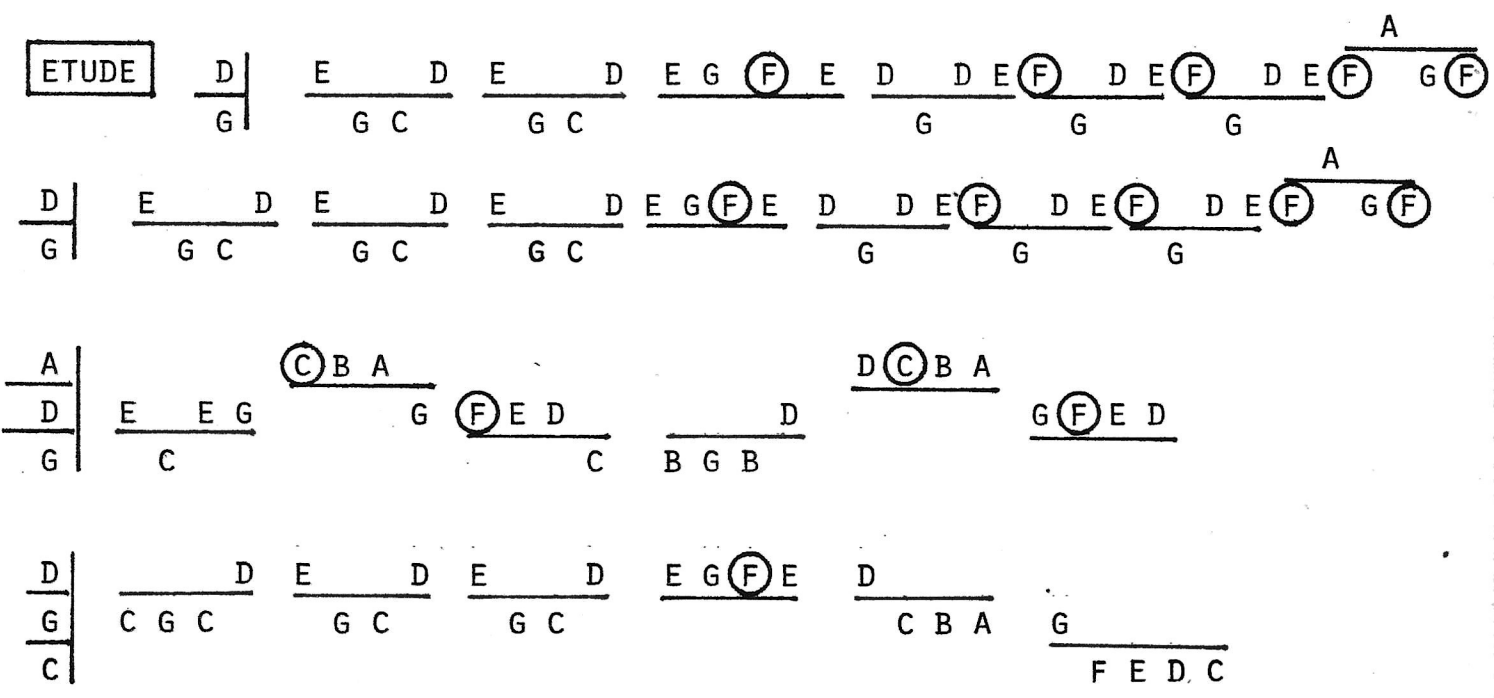

Rhythm Training

PWZUKI Books 1 - 2

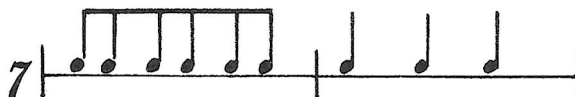
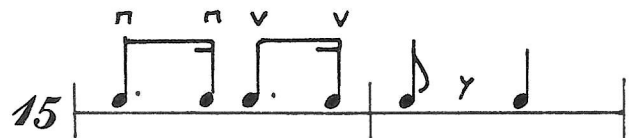
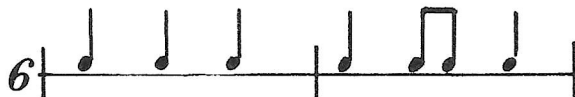
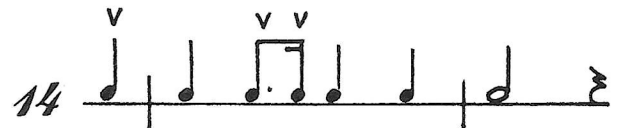
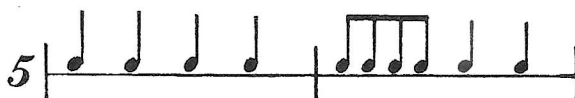
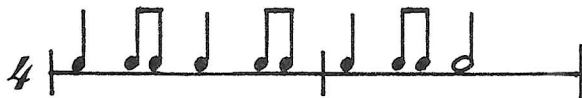
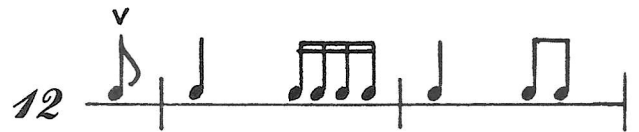
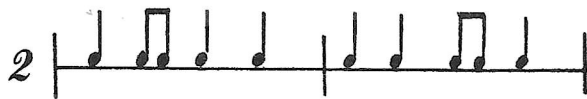
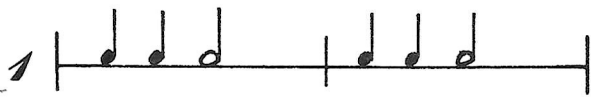

- | | |
|----------------------|-----------------------|
| 1 Lightly Row | 10 Handel Chorus |
| 2 Go Tell Aunt Rhody | 11 Allegretto |
| 3 May Song | 12 Hunter's Chorus |
| 4 Long, Long Ago | 13 Waltz |
| 5 Allegro | 14 The Two Grenadiers |
| 6 Minuet No. 1 | 15 Witches' Dance |
| 7 Minuet No. 2 | |
| 8 Minuet No. 3 | |
| 9 The Happy Farmer | |

REVIEW ALL PREVIOUS PIECES AND EXERCISES

DOWN UP-UP BOWING FOR MINUET 1

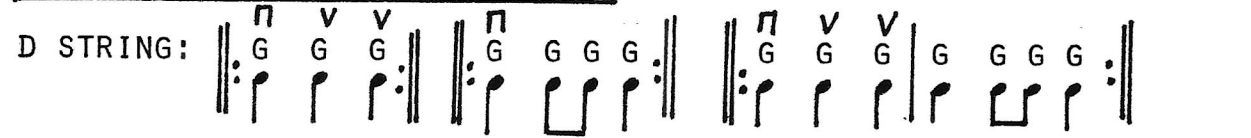
D STRING: 

$\frac{D}{G}$ | $\frac{A(4)}{C}$ (F) $\frac{A}{D}$ | $\frac{E(4)}{G}$ (C) D STRING: F# G (F) G

NOTE READING ON D STRING

TREBLE CLEF ALTO CLEF

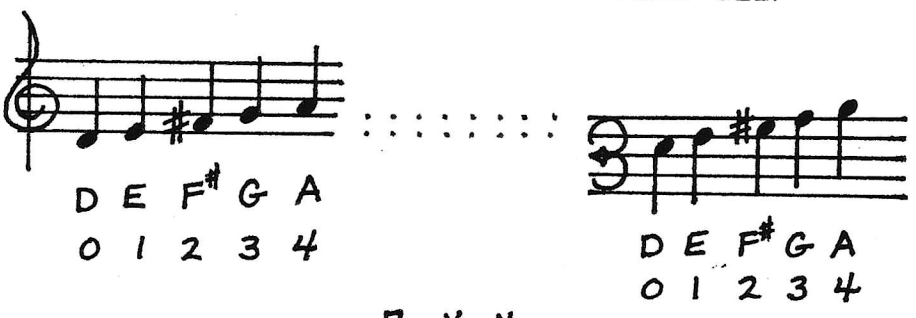

D E F# G A
0 1 2 3 4

D E F# G A
0 1 2 3 4

MINUET 1



$\frac{D}{G}$ | G G G E DE | D G (F) E D

$\frac{D}{G}$ | G (F) E D | A(4) (F) E D | C B A G B C // :||

$\frac{A}{D}$ ||: A | E F E F D G | A B A | D (C) B A | E(4) (C) | B A G F D F G

$\frac{D}{G}$ | G (F) E D | E D E (F) (F) E D | G (F) E D | A(4) (F) E D | C B A G B C // :||

REVIEW ALL PREVIOUS PIECES AND EXERCISES



MINUET 2

First system of guitar notation for Minuet 2, measures 1-2. Treble clef. Staff lines A, D, G. Circled notes C, B, C on the D string. Fingering 1, 2, 3. Dynamics: *f*. Slurs and accents are present.

Second system of guitar notation, measures 3-4. Treble clef. Staff lines A, D. Circled notes A, A, A, C, G, G, G, F, G, F, E, F, D. Dynamics: *f*.

Third system of guitar notation, measures 5-6. Treble clef. Staff lines A, D, G. Circled notes C, B, C, C, B, C. Fingering 1, 2, 3. Dynamics: *f*.

Fourth system of guitar notation, measures 7-8. Treble clef. Staff lines A, D, G. Circled notes A, G, F, E, D, G, F, E, D, D, E, F. Dynamics: *f*. Ends with repeat signs. Text: *repeat first half of Minuet 2*

Fifth system of guitar notation, measures 9-10. Treble clef. Staff lines A, D, G. Circled notes C, B, A, C, B, A, B, C, B, A, B, A. Dynamics: *mf*. Includes repeat signs and accents.

Sixth system of guitar notation, measures 11-12. Treble clef. Staff lines A, D, G. Circled notes B, C, D, A, B, C, C, B, A, A, A. Dynamics: *p*. Includes slurs and accents.

Seventh system of guitar notation, measures 13-14. Treble clef. Staff lines D, G. Circled notes D, E, F, G, F, E, F, D. Dynamics: *p*. Includes slurs and accents. Text: *now 3rd & 4th line, then repeat second half of Minuet 2*

TREBLE clef staff with fingerings 0-4 for notes A, B, C#, D, E.

ALTO clef staff with fingerings 0-4 for notes A, B, C#, D, E.

TREBLE clef staff with fingerings 0-4 for notes G, A, B, C, D.

ALTO clef staff with fingerings 0-4 for notes G, A, B, C, D.

MINUET 3 *play 1-2-1-3, then repeat; then play 4-5-6-7, then repeat 4-5-6-7*

1

2

// now play
first line
and then
third line

3

// :||

4

5

6

7

NOTICE THE KEY SIGNATURE !!!

IF NO SHARPS, NO FLATS - IT'S THE KEY OF C

C Scale - two octaves

A		(B)	(C)	○	○
D		(E)	(F)	○	○
G		○	○	(B)	(C)
C		○	○	(E)	(F)
		1	2 3	4	

IF ONE SHARP (F#) - IT'S THE KEY OF G

G Scale - 1 octave

A		(B)	(C)	○	○
D		○	○	(F#)	(G)
G		○	○	(B)	(C)
C		○	○	(F#)	(G)
		1	2	3 4	

IF TWO SHARPS (F# C#) - IT'S THE KEY OF D

D scale - two octaves

A		○	○	(C#)	(D)
D		○	○	(F#)	(G)
G		○	○	○	○
C		○	○	(F#)	(G)
		1	2	3 4	

IF TWO FLATS (B^b E^b) - IT'S THE KEY OF B FLAT

B^b Scale - 1 octave

A		(B ^b)	○	(D)	(E ^b)
D		(E ^b)	○	○	○
G		(A)	(B ^b)	○	○
C		(D)	(E ^b)	○	○
		1	2	3 4	

LIGHTLY ROW - KEY OF B FLAT

FINE

D.S. al Fine